

## Piedino di Livellamento Fisso con Perno in Acciaio Zincato

### Levelling Fixed Foot with Zinc Plated Stud

COD.	A	M	B	H	H1	C	C1	ØD	r D	Carico Max Max Load daN	U.V.
A3EB30/0630	30	06MA	30	13	2	45	43	-	-	350	24
A3EB30/0650	30	06MA	50	13	2	65	63	-	-	350	24
A3EB30/0830	30	08MA	30	13	2	45	43	-	-	350	24
A3EB30/0850	30	08MA	50	13	2	65	63	-	-	350	24
A3EB40/0630	40	06MA	30	23	2	55	53	-	-	500	24
A3EB40/0650	40	06MA	50	23	2	75	73	-	-	500	24
A3EB40/0830	40	08MA	30	23	2	55	53	-	-	500	24
A3EB40/0840	40	08MA	40	23	2	65	63	-	-	500	24
A3EB40/0850	40	08MA	50	23	2	75	73	-	-	500	24
A3EB40/1030	40	10MA	30	23	2	55	53	-	-	500	24
A3EB40/1050	40	10MA	50	23	2	75	73	-	-	500	24
A3EB50/0650	50	06MA	50	23	2	75	73	6	17	500	24
A3EB50/0830	50	08MA	30	23	2	55	53	6	17	500	24
A3EB50/0850	50	08MA	50	23	2	75	73	6	17	500	24
A3EB50/1030	50	10MA	30	23	2	55	53	6	17	500	24
A3EB50/1050	50	10MA	50	23	2	75	73	6	17	500	24
A3EB80/1030	80	10MA	30	25	2	57	55	10	29	1000	24
A3EB80/1050	80	10MA	50	25	2	77	75	10	29	1000	24
A3EB80/1230	80	12MA	30	25	2	57	55	10	29	1000	24
A3EB80/1250	80	12MA	50	25	2	77	75	10	29	1000	24

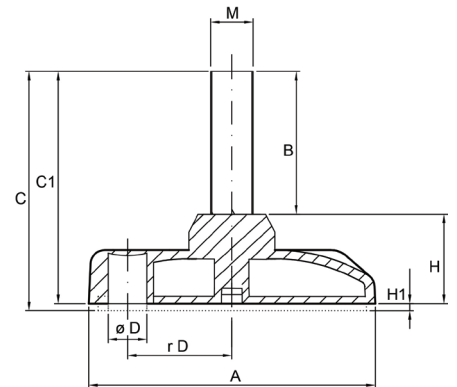

#### Caratteristiche

##### Base:

Tecnopolimero (PA) rinforzato con fibre di vetro resistente a solventi, oli e grassi.

##### Perno:

Zincato.

##### Gomma Antiscivolo:

Gomma termoplastica durezza 80 shore A, con un disegno innovativo per una migliore aderenza.

Fornita separatamente su richiesta.  
(Vedi scheda articolo SA).

#### Product specification

##### Base:

Tecnopolymer (PA) reinforced with glass fibres. Solvent, oil and grease resistant.

##### Stud:

Zinc Plated.

##### Slide-Proof Rubber:

The thermoplastic rubber, of 80 shore A in hardness, has an innovative design for a better grip.

Supplied separately on demand.  
(See. ref. SA).